

1

2

3

4

A

B

C

D

E

F

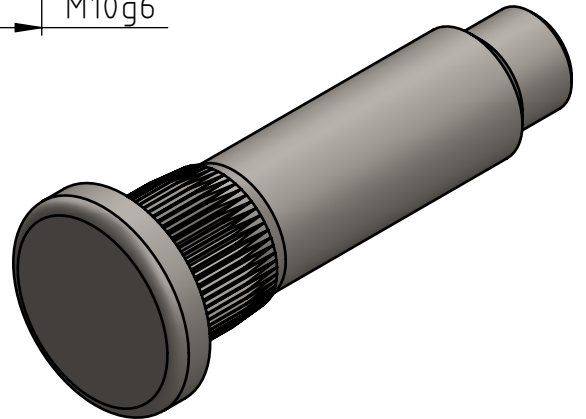
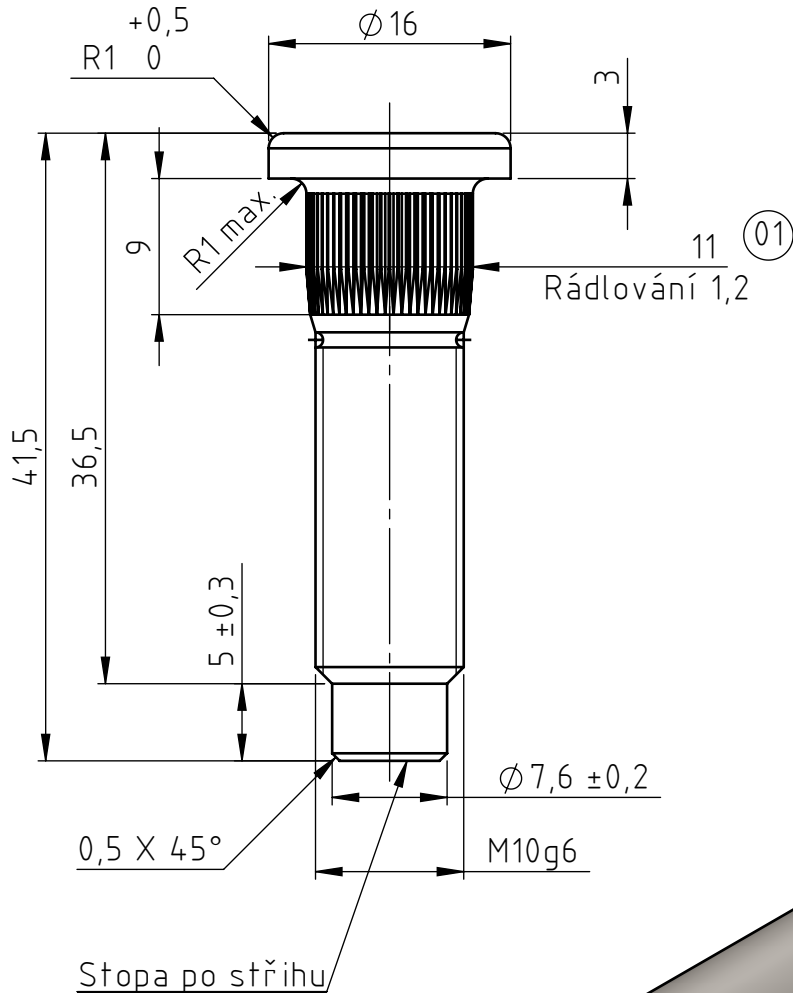

S107098

A1		Změna průměru pro rádlování		B3	4.12.2013	Kutil	01
INDEX	CHANGES			ZONE	DATE	NAME	REVISION
Všeobecné Tolerance\General Tolerances: Obrábění\Machining: ISO 2768-mL Tváření\Forming: ISO 2768-1v		FINISH:	DEBURR AND BREAK SHARP EDGES	DO NOT SCALE DRAWING	PROJECTION	A4	
Svařování\Welding: Délky\Length ISO 13920-BF Svařování\Welding: Úhel\Angle ISO 13920-AF		0.3x45°		TITLE: Šroub M10x38,5-10,9			
Odlévání do písku\Sand Casting: ISO 8062-3 - DCTG 10 - GCTG 8 Přesné odlévání\Precision Casting: ISO 8062-3 - DCTG 8 - GCTG 8		DRAWN	Kutil	19.8.2013	DWG NO.	AMD 2999.001	
The copying, distribution and utilization of this document as well as the communication of its contents to others without expressed authorization is prohibited. Offenders will be held liable for the payment of damages. All rights reserved in the event of the grant of a patent, utility model or ornamental design registration.		CHK'D	Beneš	19.8.2013	INDEX A1		
		APPV'D	Bůtora	19.8.2013	MATERIAL: 19MNB4 - 1.5523		
		MFG					
		Q.A					
NEXT ASSY	USED ON/PROJECT				SCALE: 2:1 SHEET 1 OF 1		
APPLICATION		WEIGHT: 0,27 kg					